

# TS-530A TEMPERATURE CONTROLLER Instruction Manual



Serial Number: \_\_\_\_\_



**PICOWATT**  
Veromiehentie 14  
FIN-01510 VANTAA, Finland  
phone 358 9 822087  
fax 358 9 822184  
Internet: [www.picowatt.fi](http://www.picowatt.fi)



## Contents

<b>1. INTRODUCTION</b>	<b>3</b>
<b>2. WARRANTY</b>	<b>3</b>
<b>3. SPECIFICATIONS</b>	<b>4</b>
<b>4. CONTROLS AND FUNCTIONS</b>	<b>4</b>
<b>5. PRINCIPLE OF OPERATION</b>	<b>6</b>
<b>6. INSTALLATION</b>	<b>7</b>
<b>7. RE-SCALING THE OUTPUT CURRENTS</b>	<b>8</b>
7.1. WHY TO RE-SCALE	8
7.2. CHANGING THE CURRENT SENSE RESISTORS	10
7.3. TUNING THE SYSTEM RESPONSE	10
<b>8. RECALIBRATION</b>	<b>11</b>
8.1. WHY AND WHEN	11
8.2. ABSOLUTE CALIBRATION	11
8.3. RELATIVE CALIBRATION	11
<b>9. COMPUTER CONTROL OF THE TS-530A</b>	<b>12</b>
9.1. CONNECTING THE TS-530A AND AVS-47 TOGETHER	12
9.2. INITIAL STATE AFTER POWER-ON	12
9.3. INITIAL STATE AFTER RESET COMMAND	12
9.4. COMMAND SYNTAX	12
9.5. COMMAND REFERENCE FOR THE AVS47-IB	12
9.6. COMMAND REFERENCE FOR THE PICOBUS PRIMARY INTERFACE	13
9.7. SET POINT	13
9.8. PROPORTIONAL GAIN	13
9.9. INTEGRATOR TIME CONSTANT	13
9.10. DERIVATOR TIME CONSTANT	14
9.11. POWER BIAS	14
9.12. POWER RANGE	14
<b>10. SIMULTANEOUS THERMOMETRY AND CONTROL</b>	<b>15</b>
<b>APPENDICES</b>	<b>15</b>

## 1. INTRODUCTION

The TS-530A is a precision low-power PID temperature controller designed especially for dilution cryostats. Its heating power ranges from nanowatts to about 1 W and it can take input from almost any thermometer giving a positive analog output voltage.

The TS-530A is mainly used together with the AVS-47 Resistance Bridge, and then it provides the additional advantage of sharing a common computer interface with the bridge. This not only saves one interface port of your computer, or one GPIB address, but it also simplifies programming, as the thermometer and controller can be handled by the same program routines.

Whereas thermometry below 1K may sometimes be tricky, the TS-530A is quite easy to use and you are likely to do everything right by intuition. If you are using our AVS-47 already, the only thing you have to do is to plug in the interconnection cable and connect the heater.

This manual discusses the subject of how to control temperature only very briefly, but the functions of the TS-530A are described in detail. Operating principle is explained with the aid of a block diagram. The latter part of this manual is devoted to interfacing the TS-530A with a computer through the AVS-47.

It is in our interest to help you get maximum use of this instrument and its performance. Should you have any questions, problems or suggestions, you are welcome to contact us.

The TS-530A is a direct successor of our previous model TS-530. The two models do not differ in performance, but the TS-530A contains improvements regarding the immunity against electrostatic discharges and radiated field. Also the emitted RF interference level has been reduced to a practically nonmeasurable level.

In order to improve the immunity, it was necessary to make significant changes in the grounding scheme. This, in turn, led to change in the analog input and heater output connectors. These are the only changes that affect the compatibility between the older and the newer models.

Some operations to the instrument require that it be opened. There may be hazardous voltages inside the unit, which one can touch. Therefore, such operations are allowed only for a qualified serviceman: "A person having appropriate technical training and experience necessary to be aware of hazards to which he is exposed in performing a task, and of measures to minimize the danger to him or other persons".

## 2. WARRANTY

**Picowatt** warrants this product to be free from defects in material and workmanship. Our liability under this warranty is limited to repairing or replacing any instrument or part thereof which, within **three years** after the shipment to the original purchaser, proves defective. This warranty is void if the instrument has not been used according to the instruction manual, or if it has been used under exceptional environmental conditions (see below).

In need of warranty repair, the instrument must be returned to **Picowatt**, by prepaid airfreight, and with a detailed description of the fault or malfunction following the instrument.

The name and address/telefax/telephone number or Email address of a person who is able to give supplementary information should be included whenever possible. **Picowatt** will pay the return shipment of the instrument, if the repair was covered by warranty.

If no fault is found, or if there is a strong indication that the warranty is void, the purchaser is charged for all freight and shipping costs in addition to the repair. Therefore it is recommended that **Picowatt** be contacted prior to shipment, so that we can give instructions for additional tests or simple component replacements and unnecessary shipments may be avoided.

**CAUTION:** the TS-530A is a delicate laboratory instrument. It has been designed only for the purpose of controlling temperature by means of supplying current to a passive heater resistor. Using this instrument for any other purpose will void the warranty and may cause permanent damage to the instrument.

The TS-530A has been designed to operate in a laboratory environment, which means normal living room atmosphere, temperature, humidity and purity of air. The unit does not tolerate continuous vibration or hard shocks.



### 3. SPECIFICATIONS

**SET POINT** Range from +500 $\mu$ V to +4.2000V.  
Resolution 100 $\mu$ V, risetime 1s.

**INPUT SIGNAL** Analog output from any thermometer. Input range 0...+4.2V. Both positive and negative dV/dT is acceptable. Input current less than 1  $\mu$ A.

**ERROR AMPLIFIER** Switched-capacitor amplifier has proportional gains from 5 dB to 60 dB in 5 dB steps. Bandwidth (-3 dB) is 10 Hz.

**ERROR METER** Centered analog meter with high sensitivity around zero and reduced sensitivity at the ends of the scale.

**INTEGRATOR** Analog integrator with time constants 2, 5, 10, 20, 50, 100, 200, 500 and 1000s. A reset position is provided for PD control mode, and a latch position for temporary storage of accumulated charge.

**DERIVATOR** Modified derivator has dominant time constants 0, 1, 2, 5, 10, 20, 50 and 100s. Derivator has a 20 dB/dec roll-off for frequencies above 10 Hz.

**POWER BIAS** A constant amount of power can be applied to the heater. Possible values are 0, 20, 40, 60, 80 and 100% of the maximum power of the selected output range.

**POWER AMPLIFIER** Linear current source with low ripple and noise. Maximum output power is  $(0.1A)^2 * R_H$  or  $(9V)^2 / R_H$ , whichever is less.

Nominal power ranges from 1  $\mu$ W to 1W are obtained with a 100 $\Omega$  heater. Other heater values can also be used, and it is possible to re-scale the output currents so that the power ranges will be exact powers of ten.

The heater output power of the TS-530A is a linear function of the error signal. Therefore the gain of the system remains constant regardless of power level.

**POWER METER** Analog meter indicates either true dissipated power ( $I_H * V_H$ ), or percentage of maximum current of the range.

### 4. CONTROLS AND FUNCTIONS

**SET POINT** This 5 digit code switch is used to determine the manual set point voltage, which is compared with the analog input voltage, as applied to the rear panel input connector. One step corresponds to 100  $\mu$ V, and the maximum setting is 4.2000 V. Lowest allowed setting for the code switch is 00001.

**ENTER BUTTON** The code switch can be dialled safely without danger of unwanted jumps in output power. The new setting does not become current until the ENTER switch is pressed. The ENTER LAMP indicates whether the current set point was last entered from the code switch or through the computer interface.

**dR/dT SWITCH** This switch is one of those three functions that are only manually accessible. Use it to change the polarity of the control loop to be suitable either for sensors with positive temperature coefficient, like Pt or RhFe, or negative, like Ge and carbon. Note that in any case, the output from your thermometer must be a positive voltage.

**ERROR SHORT SWITCH** This switch is used to force the internal error signal to zero. Then the heater output will depend only on the bias power setting and charge stored in the integrator, and this charge is changing only very slowly, as there is no error voltage to integrate. This switch allows you to make temporary arrangements at the controller input while retaining the present level of heater power.

**GAIN** Proportional gain is provided by the error amplifier. At full 60 dB gain, a 5 mV error voltage will produce the maximum output of the selected power range. Proportional gain is a common factor also to the integrator and derivator circuits. This makes the integrator and derivator time constants independent of gain.

**INTEGRATOR** Integrator time constant can be selected from 9 logarithmically spaced discrete values 2...1000 seconds. The integrator can be reset at both ends of the scale for convenience. An infinite (= very long) time constant allows the integrator to be latched so that it retains its contents even though error voltage is nonzero. The analog integrator will, however, drift slowly either up or down, and therefore infinite position should be used only for a short time.

**DERIVATOR** Derivator provides additional, frequency dependent forward gain with +90 degrees phase shift, and it is used to reduce overshoot or speed up step response. This gain will also amplify system noise. With  $T_D = 100$  s the maximum gain magnitude of 100 (40 dB) will occur at 1 Hz frequency. Do not use a long derivator time constant and a high proportional gain at the same time, as this will make the heater output noisy and unstable. In zero position the derivator is turned off.

**POWER BIAS** Power bias switch allows the user to apply a constant amount of heating power. This power, indicated as percentage of the maximum power of the selected range, is independent of proportional gain. Power bias is especially useful in PD control mode, where a properly set bias can greatly reduce control error. Five evenly spaced power levels are provided.

**POWER RANGE** Power range indicates the nominal maximum power that is available on that selected range with standard current sense resistors and a 100 $\Omega$  heater. For any other heater value, following rules apply:

TS-530A can deliver a maximum heater current of 100 mA on highest range, 30 mA on the lower, then 10 mA etc. For heater values less than 100 $\Omega$ , the **available current** determines the maximum power.

Maximum output voltage is about 9 V. for heater values greater than 100 $\Omega$ , it is this **voltage** that limits maximum power on the highest range to a value of  $(9V)^2/R_H$ .

On zero range, there will be a small current, depending on error signal, flowing to sensor. This should stay below 10  $\mu$ A. If you have a high-resistance heater, this may still cause some heating. Then use the OUTPUT SHORT switch.

When the zero power range and current display mode are selected, the output meter shows how much current, as percentage of the full range current, would flow to heater on any range other than zero.

**OUTPUT SHORT** The output short switch provides a rapid shutdown of heater output without need to switch the power range all the way down. Further, the output leakage is much lower when this switch is used.

**ERROR METER** The error meter indicates the magnitude of the error voltage, amplified by proportional gain. The meter has a nonlinear response, so that its sensitivity is highest in the middle, and lower at both ends of the scale. The purpose of this arrangement is to make trends visible also when the error is large while permitting high resolution near to balance.

Deflection from center to the first division corresponds to about 0.2 V at the amplifier output, and full deflection to about 5 V.

### POWER METER

**METER SWITCH** The power meter has two display modes that are selected by the METER switch. In power mode, the meter indicates true power dissipated in the sensor ( $V_H * I_H$ ). Heater resistance does not affect calibration of the meter. Full deflection corresponds to maximum power of the selected power range. In current mode, full deflection occurs at the maximum output current of the selected range.

Power mode is usually more readable, as it has a linear scale. 10% of maximum current heats by 1% of maximum power, which is easily forgotten when looking at a meter that shows the current only. However, you will find current mode more useful, if your heater resistance is something very different from 100 $\Omega$ .

Selecting the "current" display mode and zero power range, you can verify the heater output level in advance, before activating the output.

**MAINS SWITCH** When power is turned on, gain will have its lowest value, integrator and derivator are reset, and power bias and output range are at zero. Set point may be random, and must be entered using the ENTER switch .

**INPUT CONNECTOR** A BNC connector, jacket grounded. (Analog cables made for the TS-530 are not suitable for the TS-530A).

**DATA CONNECTOR** The TS-530A can be interfaced with a computer through the AVS-47 Resistance Bridge. For that purpose, a 37-way ribbon cable must be connected from the data connector to the programming output connector of the AVS-47. This connector also provides access to the DAC output and other monitor output voltages.

**HEATER OUTPUT** Two connector types are provided for the heater. If the heater wires come up from the cryostat as one coaxial cable, you can use the rear panel BNC connector.

In case of two coaxial cables, connect the low end of the heater to the TS-530A ground by using the black banana terminal.

Please note that the

**BNC JACKET IS CONNECTED BOTH TO THE TS-530A ENCLOSURE AND TO THE CIRCUIT GROUND.**

This arrangement is necessary in order to protect the output stage against electrostatic discharges.

Heater output is also available at the two banana terminals. Connect the black terminal to the shield of the heater cable, if a shield exists.

*Only one BNC connector is used in the TS-530A in order to remind, that the minus-pole of the heater output is always firmly grounded to the enclosure of the instrument, whereas in the TS-530, the enclosure was isolated from the circuit ground.*

**MAINS INPUT** The TS-530A should be connected to a grounded mains outlet for electrical safety. Mains ground is internally connected to the metal case of the instrument and to the circuit ground. Mains input is RFI filtered. The filter has an earth-line choke. The two selectable voltage ranges are 180-240V and 90-120V.

**PRIMARY FUSE** The standard primary fuse ratings are:  
180-240V: 100 mA-T (slow action)  
90-120V: 200 mA-T (slow action)  
Fuse size is 5x20 mm.

**SECONDARY FUSES** New units are equipped with three self-resetting fuses. The first TS-530A controllers were equipped with three 5x20mm slow (T) fuses: F701 and F703 = 160 mA and F702 = 100 mA.

**INTERFACE CONNECTOR** The DC37 -type interface connector is used to relay programming commands from the primary computer interface unit of the AVS-47 Resistance Bridge to the TS-530A. In addition, this connector provides access to various signals that can be used to monitor the controllers operation. Refer to appendix E for pin assignments.

## 5. PRINCIPLE OF OPERATION

The operating principle of the TS-530A is briefly described with the aid of a simplified block diagram .

Analog output from a thermometer and a set point voltage from the internal set voltage source are applied to the controller input. Error signal is formed by a switched capacitor amplifier, which also provides the proportional gain.

The amplified error signal is fed to a summing amplifier as such, but it is also fed to the integrator and derivator sections. The integrator is an analog, low-drift circuit, whose time constant (it is actually gain rather than a time constant) is varied by adjusting voltage division of R1 and R2, and the input resistor R3.

The derivator has been modified from the basic, pure derivator circuit, in order to reduce its sensitivity to noise and to stabilize its gain. Derivator time constant is varied by changing R4 and R7 simultaneously. R4 is used to determine the time constant, but because it also affects the pass-band gain of the derivator, a gain compensation is done by making  $R5/R4 = R6/R7$ .

Signals from the error amplifier, integrator and derivator, plus a selectable constant voltage ( bias power) from a voltage divider, are all applied to the summing amplifier with equal weights. This PID output voltage is a linear function of the error voltage. If this voltage was used to drive the heater output, then the heating power and therefore also the change in temperature, would no longer depend in a linear but quadratic way on the input ( $P=I^2 \cdot R$ ). To prevent this, and to make the overall system as linear as possible, a square root is taken of the PID output before driving the power stage.

The power amplifier is a linear series-pass transconductance amplifier, whose output is a current proportional to the input. Although more complicated, current output has been used rather than a voltage output because it is inherently short-circuit protected and can be used with any heater resistance value. The output range is selected by changing  $R_s$ .

The level of the heater current is shown by the output meter . For convenience, this meter has also a power display mode, which shows the true dissipated power as calculated from  $V_H \cdot I_H$ . Calculation is made by a pulse height-width circuit that produces a continuous pulse train, so that pulse height is proportional to heater voltage and pulse width is proportional to heater current.

The manual set point information is obtained from a 5-decade front panel code switch . This is in BCD format which is not suitable for the digital-to- analog converter . Therefore it is first converted to a binary number.

Set point can also be given remotely, from the computer interface that is installed in the AVS-47 Resistance Bridge. An internal serial format is used for this purpose. The serial data is stored in a shift register, from which it is immediately transferred to the set point memory. But whenever the front panel “ENTER” switch is pressed, the contents of the set point memory is replaced by data from the front panel code switch.

The low-speed digital-to-analog converter is of proprietary integrating type. Its conversion cycle consists of four phases. During phase 1, the integrator integrates an adjustable input voltage for a length of time that corresponds to the set point data. After that, the integrator is stopped and its voltage is transferred to a sampling low-pass filter. Time used for this second phase is constant. During the third, or calibration phase, integration is continued for a third period of time, which depends on the set point data. The final integration result is compared with a calibration reference voltage and depending on the comparison result, the integrator input is either increased or decreased until it has an exactly correct value.

Note that zero is a forbidden value for the set point - the integrator must be allowed to integrate for at least one clock -cycle.

## 6. INSTALLATION

### MAINS VOLTAGE

**IN ORDER TO MAINTAIN ELECTRICAL SAFETY, THE TS-530A MUST BE CONNECTED TO A GROUNDED MAINS OUTLET.**

The unit has two mains voltage ranges: 180-240V (maily for the Europe), and 90-120V (mainly for Japan and the USA).

The mains voltage setting of the TS-530A must be checked before connecting the power. The voltage setting is written on the identification label on the rear panel. If the setting does not correspond to your local mains voltage, the setting must be changed. Also, if the marking is unclear, the TS-530A must be opened and the voltage setting must be verified from inside.

**OPENING THE TS-530A AS WELL AS CHANGING OF THE MAINS VOLTAGE SETTING IS ALLOWED ONLY FOR A QUALIFIED SERVICEMAN.**

#### INSTRUCTIONS FOR A SERVICEMAN:

To change or verify the mains voltage setting, **disconnect the power cord from the instrument** and then open the top cover of the TS-530A. The cover is opened by first removing the four screws at the corners. Then insert a sharp knife or a small screwdriver between the cover and the enclosure at the side of the instrument. Use the knife to lift the cover plate. Locate the mains transformer (in the right front corner), and the two connectors on the right side of the transformer. The connector headers are marked “115V” and “230V” on the circuit board. These markings mean 90-120V and 180-240V . The socket with two jumper leads must be in the position that corresponds to your local mains voltage. If necessary, use pliers to lift the jumper sockets from their places and exchange the positions of the empty socket and the socket with the jumper leads. **Do not pull from the leads!**

After having changed the voltage setting, correct the marking on the rear panel identification label to correspond to the new setting.

#### **THE PRIMARY FUSE MUST ALSO BE REPLACED!**

Remember to replace the primary fuse after having changed the mains voltage setting.

The physical size of the fuse is 5 x 20 mm

Primary fuse: 90-120V	200 mA - T (slow action)
180-240V	100 mA - T

**INPUT** Analog input is connected to a BNC socket.

An input cable for connecting the TS-530A to the AVS- 47 Resistance Bridge is supplied with the controller. Any other coaxial cable with 50-ohm BNC connectors can also be used.

The input should be taken from a low-impedance source, preferably less than 100Ω. With a high source impedance, the input current of the error amplifier will reduce accuracy.

**NOTE :** The output resistance of the old Model AVS-45 Resistance Bridge is 1kΩ. To reduce this, replace resistor R417 (1kΩ) by a 100Ω resistor. The cable from the AVS-45 to the TS-530A should be as short as possible in order to prevent the driving op amp from oscillating. See appendix B for R417 location.

**HEATER** The heater should be floating in order to avoid any feedback from the controller output to either controller or thermometer input, which can occur if the heater current is allowed to flow via a ground path common with the input.

Two types of output connectors are provided, BNC and banana sockets. The jacket of the BNC socket is connected to the enclosure and the circuit ground. Also, the black banana socket represents both the circuit and safety ground. Regardless of which connector type you use, the cable shield must be connected to the TS-530A enclosure for good protection against EMI and electrostatic discharges.

The nominal output power ranges from 1μW to 1W are obtained when the heater resistance is 100Ω.

If  $R_H < 100\Omega$  then it is equation  $P = I_{max}^2 * R_H$  that indicates the maximum attainable power on each output range.  $I_{max}$ , in turn is calculated as follows:

$$I_{max} = 1V/R_s \quad (R_s = 10k, 3k16, 1k, 316\Omega, 100\Omega, 31.6\Omega \text{ or } 10\Omega \text{ for ranges } 10\mu W..1W)$$

If  $R_H > 100\Omega$  then the TS-530A cannot supply more power than  $(9V)^2/R_H$  on any range. Assume, for example, that the heater resistance is 500Ω. Heater current would be  $1V/10\Omega=0.1A$  on the highest and  $1V/31.6\Omega=31.6mA$  on the second range. These currents would rise the heater voltage up to 50 and 15 Volts, respectively. Therefore,  $81/500= 0.162W$  is the maximum power on the two highest ranges.

**CONTROL POLARITY** The TS-530A can be used with sensors having either a positive temperature coefficient (like Platinum and Rhodium-Iron sensors) or a negative coefficient (like Germanium and Carbon resistors, and Silicon diodes). Depending on which type of sensor is being connected, set the front panel dR/dT switch in corresponding position.

It is not necessary to remember the polarity of the sensor when looking at the error meter. A positive deflection means always that more power is needed to reach balance and that the integrator (if active) is working to increase output power.

## 7. RE-SCALING THE OUTPUT CURRENTS

### 7.1. WHY TO RE-SCALE

Re-scaling the output current may be desirable for one or more of following reasons:

- 1) Heater resistance is much lower than 100Ω. One cannot make use of the power meter 's full deflection. Output currents may be increased to improve meter readability.
- 2) Heater resistance is much higher than 100Ω. Heater currents may be reduced to prevent saturation of output voltage.
- 3) Operating convenience can be improved by adjusting the output ranges to be exact powers of ten.





TABLE OF CURRENT SENSE RESISTORS

	R526	R533	R527	R532	R528	R537	R529
RANGE	0.1μW	1μW	10μW	100μW	1mW	10mW	100mW
RH							
25	15k8	4k99	1k58	499	158	49.9	15.8
50	22k6	7k15	2k26	715	226	71.5	22.6
75	27k4	8k66	2k74	866	274	86.6	27.4
100	31k6	10k0	3k16	1k00	316	100	31.6
150	38k3	12k1	3k83	1k21	383	121	38.3
200	44k2	14k0	4k42	1k40	442	140	44.2
300	54k9	17k4	5k49	1k74	549	174	54.9
400	63k4	20k0	6k34	2k00	634	200	63.4
500	71k5	22k6	7k15	2k26	715	226	71.5
1000	100k	31k6	10k0	3k16	1k00	316	(100)
RANGE	0.5μW	5μW	50μW	500μW	5mW	50mW	500mW
RH							
25	7k15	22k6	715	226	71.5	22.6	7.15
50	10k0	3k16	1k00	316	100	31.6	10.0
75	12k1	3k83	1k21	383	121	38.3	12.1
100	14k0	4k42	1k40	442	140	44.2	14.0
150	17k4	5k49	1k74	549	174	54.9	17.4
200	20k0	6k34	2k00	634	200	63.4	(20.0)
300	24k9	7k87	2k49	787	249	78.7	(24.9)
400	28k7	9k09	2k87	909	287	90.9	(28.7)
500	31k6	10k0	3k16	1k00	316	100	(31.6)
1000	44k2	14k0	4k42	1k40	442	140	(44.2)
RANGE	1μW	10μW	100μW	1mW	10mW	100mW	1W
RH							
25	4k99	1k58	499	158	49.9	15.8	5
50	7k15	2k26	715	226	71.5	22.6	7
75	8k66	2k74	866	274	86.6	27.4	9
100	10k0	3k16	1k00	316	100	31.6	10
150	12k1	3k83	1k21	383	121	38.3	(12.1)
200	14k0	4k42	1k40	442	140	44.2	(14)
300	17k4	5k49	1k74	549	174	54.9	(17.4)
400	20k0	6k34	2k00	634	200	63.4	(20.0)
500	22k6	7k15	2k26	715	226	71.5	(22.6)
1000	31k6	10k0	3k16	1k00	316	100	(31.6)

NOTE 1: Figures in parenthesis represent values that give correct power display and voltage monitor output, but due to the compliance voltage limit, indicated maximum power will not be reached.

NOTE 2: The ratio of successive values in a row should be 3.16

NOTE 3: General formula for calculating a current sense resistor for any range-heater combination is

$$R_s = 1V/\sqrt{((full\_range\_power)/R_H)}$$

## 7.2. CHANGING THE CURRENT SENSE RESISTORS

**REPLACING THE CURRENT SENSE RESISTORS REQUIRES OPENING THE INSTRUMENT AND IS THEREFORE ALLOWED ONLY FOR A SERVICEMAN.**

### INSTRUCTIONS FOR A SERVICEMAN

**Before opening the top and bottom covers of the TS-530A, disconnect the power cord from the instrument.**

Locate the seven dual-in-line reed relays K501-507 at the rear of the analog board 53A\_ANAx (appendix D). Behind the relays, you find the current-sense resistors.

Unsolder the standard resistors and replace them by new values, values taken either from the table on the previous page or calculated by yourself. Use the nearest value from the so-called "E96 series".

## 7.3. TUNING THE SYSTEM RESPONSE

Because in a low temperature system, thermal properties like heat capacitance and thermal conductivity may change drastically with temperature, it may be reasonable to use just a fast and simple way to find some working controller settings and to repeat this at various temperatures.

For example, following method can be tried. Select an output power range, which is assumed to provide sufficient control power. Using the TS-530A as a proportional controller, with no integrator and no derivation, increase gain until there is some 10 to 20% overshoot. Then add derivation, step by step, by increasing TD. This usually reduces overshoot, and it is often possible to get a quite satisfactory step response.

The function of the derivator is to provide additional frequency dependent gain. Input to the derivator is taken from error amplifier output, and therefore this gain can have an opposite effect on output than the proportional gain, which is the useful feature. If properly set, derivator allows one to use a higher proportional gain to make system faster and more accurate while keeping overshoot within acceptable limits. Unfortunately, a proportional-differential controller, while simple to tune, is not sufficiently accurate for many applications.

Because the DC-gain in the PD-mode is finite, and it cannot be further increased without making the system unstable, there will be a certain amount of control error between the desired set point and the temperature that the system actually reaches. This control error can be minimized, while still using PD mode, once the approximate heater power for this temperature is known. Use the POWER BIAS feature to apply a constant power to the heater, which is near to **but less** than the required control power. The correction that the PD circuit now has to make is much smaller and so will also be the control error.

It is not always possible to set the bias power and check frequently if it should be changed. Then the integrator can be switched on to cancel the **steady-state control error**. Integrator accumulates the existing error voltage, as long as there is any, and increases or decreases the heater power by an amount proportional to the accumulated charge. Ideally, the system will slew exponentially towards the set point and finally stay there, within some limits due to noise and integrator input errors.

Problem with the integrator is that it impairs the system stability, and very easily causes unacceptable overshoot. It is usually overshoot, not oscillation, that determines how short TI one can use. Try to make the integrator time constant shorter (this increases the integrating action), until overshoot is some 10%. Then verify that there is enough damping, i.e. system approaches steady state without prolonged oscillations. If damping is too low, reduce proportional gain slightly. Usually the result is not so awfully far from optimum.

The TS-530A integrator has been designed so that it is possible to change TI during control. Step response can be improved by first selecting a long TI to prevent unnecessary integration of error when it is large, and restoring final TI when the PD controller has done what it can. This is especially useful in applications involving a computer, where the above sequence can be easily automated.

**NOTE:** The derivator can provide a maximum of 40dB gain at 1Hz frequency. A combination of 60dB proportional gain and 100s derivator time constant will amplify noise coming with signal and set point voltage as well as from the error amplifier itself by a factor of  $10^5$ . Heater output will be noisy and control accuracy less than with a shorter TI.

## 8. RECALIBRATION

### 8.1. WHY AND WHEN

The TS-530A has been designed to be free from frequent need of calibration. However, because the input to the controller is taken from an external thermometer, it is necessary to take care that the offset and scale factor of the TS-530A set point correspond to those of the thermometer. If this adjustment is not made, the system will not reach the desired set point, and the thermometer display will not conform to the set point data.

When the TS-530A is shipped, it has been calibrated in **either** of the two ways:

**Absolute calibration** : A unit that is delivered alone is calibrated against an external precision voltmeter so that offset is as small as possible (ideally zero) and scale factor 1.00000 (this means that set point data of 10000 produces an analog set point voltage of exactly 1.00000 Volts).

**Relative calibration** : If the unit is ordered together with an AVS-47 Resistance Bridge, the bridge is first calibrated against an external standard in order to establish an accurate relationship between measured resistance and the analog output and digital display of the AVS-47. With both instruments connected together, the offset of the TS-530A set point is then adjusted to match the offset of the AVS-47 analog output. Using the AVS-47 in self-calibration mode, the scale factor of the set point is calibrated so that error signal is zero for set point data=10000.

The **latter** method is preferred whenever it can be used. The control system cannot be more accurate than the thermometer, and if one has to rely on the thermometer anyway, a different calibration of the controller, even though it were more accurate, would make things complicated.

Need for recalibration is simple to realize. The steady-state reading of the thermometer should correspond to set point within a few hundred microvolts (or set point units) for a properly calibrated system. If the resistance bridge and the TS-530A are of different ages, relative calibration is likely to be needed.

BOTH THE ABSOLUTE AND RELATIVE CALIBRATION, AS WILL BE EXPLAINED BELOW, REQUIRE OPENING THE TS-530A AND THEREFORE THESE OPERATIONS ARE ALLOWED ONLY FOR A SERVICEMAN.

### 8.2. ABSOLUTE CALIBRATION

Short-circuit the analog input BNC connector. Let the TS-530A warm up for at least half an hour at the same temperature where you plan to use it. Connect a high-quality digital voltmeter between the test pins "DAC\_OUT\_HI" and "DAC\_OUT\_LO" on the leftmost "digital board 53A\_DIG". The voltmeter should have a 2 Volts range with at least 10 $\mu$ V resolution. Input resistance of the DVM should be greater than 100M $\Omega$ .

Dial the set point to 100 and press <ENTER>.

Locate trimmer R419 on the digital board 53A\_DIGx and adjust DAC offset for output voltage of 10.00mV. Note that 00000 is a forbidden value for the set point code switch (accuracy is not very good in the neighbourhood of zero, either).

Dial the set point to e.g. 19000 (= 1.9000 Volts; you can use also any other reading, higher than 10000, which is within your digital voltmeter's range and not greater than 4.2 Volts. Press <ENTER> and let the voltage stabilize. Locate trimmer R410 and adjust scale factor for correct reading.

### 8.3. RELATIVE CALIBRATION

No external instruments are needed for calibrating the TS-530A for use with the AVS-47 Resistance Bridge.

Connect the two instruments together with the coaxial cable supplied with the controller (always use the ANALOG output of the AVS-47, not DEVIATION). If the system is to be operated remotely, plug in also the data interconnection cable (this may change calibration slightly as it provides an additional ground path). Toggle the bridge input to **CAL**, the range to **200k $\Omega$** , the excitation to 3mV, and the TS-530A set point code switch to 10 and press <ENTER>. Let the system warm up for at least half an hour.

Adjust the OFFSET trimmer of the AVS-47, if necessary, so that the display reads 000.10 (= 0.1 k $\Omega$ , there should be no need to do this if the bridge was self-calibrated correctly). Select the highest proportional TS-530A gain of 60dB. If the ERROR meter is not exactly centered, use trimmer R419 (board 53A\_DIG) to null the error signal. The smallest division of the meter corresponds to two display units of the AVS-47.

Change the range of the AVS-47 to **200 $\Omega$** . Dial the code switch to 10000 and press <ENTER>. The bridge should read 100.00 (if it does not, use the front panel SCALE trimmer for self-calibration), and the ERROR meter should be centered again. If not, use R410 (53A\_DIG board) to center the meter.



## 9. COMPUTER CONTROL OF THE TS-530A

### 9.1. CONNECTING THE TS-530A AND AVS-47 TOGETHER

It is possible to control the TS-530A remotely through the AVS-47 resistance bridge, using either its primary interface alone, or the AVS47-IB two-stage GPIB interface option. For computer control these two instruments must be connected together with a 37-way ribbon cable, which is supplied with the TS-530A.

If your application calls for use of the TS-530A internal monitor signals, then the default ribbon cable is not suitable, and you have to make a cable according to drawing 530conn.sch (APPENDIX E). A shielded 3 or 4 wire cable with the shield carrying digital ground is adequate. Keep the cable as short as possible, a few tens of centimeters.

NOTE: This manual no longer describes use of the abandoned AVSI2, DC900 nor AVS46-IB interfaces. If your bridge has been equipped with any of them, please contact Picowatt for getting old manuals.

### 9.2. INITIAL STATE AFTER POWER-ON

Regardless of whether the computer interface is connected or not, the initial state of the TS-530A after turn-on is such that all parameters are in their lowest states. Set point value may be random until the <ENTER> button is pressed. The instrument can be used manually as already described in this manual even when the computer interface is connected.

Note particularly that the integrator capacitor is reset and the integrator will start from zero when enabled.

### 9.3. INITIAL STATE AFTER RESET COMMAND

The TS-530A can be set to the reset state by commands

**AVS47-IB:** \*RST  
PONRST

These commands bring both the AVS-47 and the TS-530A to their initial power-on states. PONRST has the additional feature that it erases all scan parameters etc., except the RAM buffer of the AVS47-IB.

**Picobus:** All parameters must be reset separately using the respective commands.

### 9.4. COMMAND SYNTAX

The command syntax depends on which computer interface is being used. It is assumed here that the user has familiarized himself with the Picobus described in the AVS-47 manual, or with the AVS47-IB by reading its own manual.

### 9.5. COMMAND REFERENCE FOR THE AVS47-IB

Command separator: ; (semicolon).

Command terminator is marked by <CT> in the following. It means

- ASCII 10 decimal (<LF> =linefeed, <NL>=newline), or
- ^END = end-of-identify (physically one of the 24 GPIB signal leads), or
- both together

**NOTE:** All numeric parameters are shown in decimal format.

SPT[1..42000]<CT> set point. unit=100μV

PRO[0..15]<CT> proportional gain (0=5dB, 11=60dB, 15=error short)

ITC[0..11]<CT> integrator time constant (0,11=reset, 10=hold)

DTC[0..7]<CT> derivator time constant

BIA[0..5]<CT> power bias. unit 20% of full range

POW[0..7]<CT> power range

SPV, SPV? Measure Set Point Voltage Command, Set Point Voltage query.

HTV, HTV? Measure Heater Output Voltage Command, Heater Output Voltage query.

HTI, HTI? Measure Heater Output Current Command, Heater Output Current query.

HTP, HTP? Measure Heater Output Power Command, Heater Output Power query.

Use these four commands as pairs. Allow for a couple of seconds delay between the command and the query.



**9.6. COMMAND REFERENCE FOR THE PICOBUS PRIMARY INTERFACE**

COMMAND SEPARATOR: Command on the same line are separated by semicolons (;).

COMMAND TERMINATOR: <CR> (Carriage return, ASCII 13 decimal).

- SPT[1..42000] set the control point (\*100µV)
- PRO[0..11] set the proportional gain
- PRO[15] force the error signal to zero
- ITC[0..11] set the integrator time constant
- DTC[0..7] set the derivator time constant
- BIA[0..1] set the bias power
- POW[0..7] set the heater power range

**NOTE:** The AVS-47 must be in the remote (REM1) mode.

**EXAMPLE:** The control point is set to 1.2345 Volts by giving command SPT12345.

**9.7. SET POINT**

Set point command is

Picobus: SPTn , n= [1..42000]  
AVS47-IB: SPTn , n= [1..42000]

In decimal notation the set point ranges from 1 to 42000 times 100µV. This command overrides any previously given manual set point. A front panel LED indicator shows whether the manual or remote set point is currently being used by the TS-530A.

**NOTE:** The TS-530A does not provide means for reading the remote set point value back to the computer. If your computer program is such that set point can be given directly from keyboard, you must take care of storing the current value. For the same reason, the computer cannot find out if the ENTER button has been pressed and manual set point

activated. Do not mix manual and remote operation unless you know what you are doing.

You can read the analog set point voltage via the AVS-47, however, this voltage may differ slightly from the digital set point number.

**9.8. PROPORTIONAL GAIN**

Twelve logarithmically spaced gain values are available. Use the command

Picobus: PROn n=[0..15]  
AVS47-IB: PROn

The parameter n is selected as follows

n	decibels	gain	
15	-	0	;error forced to zero
14	60	1000	
10	55	560	
9	50	316	
8	45	180	
7	40	100	
6	35	56	
5	30	31	
4	25	18	
3	20	10	
2	15	6	
1	10	3	
0	5	1.8	

**9.9. INTEGRATOR TIME CONSTANT**

Nine logarithmically spaced integrator time constant values are available. In addition, the integrator can be latched (hold-state) to retain the accumulated charge, and it can be reset at both ends of the parameter range.

Picobus: ITCn ;n=[0..11]  
AVS47-IB: ITCn

parameter n is selected as follows:



n	TI
11	reset (PD -mode)
10	hold (TI = ∞)
9	1000 s
8	500 s
7	200 s
6	100 s
5	50 s
4	20 s
3	10 s
2	5 s
1	2 s
0	RESET (PD -MODE)

n	BIAS POWER
5	100% of full range output power
4	80%
3	60%
2	40%
1	20%
0	0

**NOTE:** Because the TS-530A has been linearized in terms of output power, changing bias power by one step will always increase or decrease heating power by an equal amount regardless of the present heater current level.

### 9.10. DERIVATOR TIME CONSTANT

Seven derivator time constant values are available, and can be selected by command

Picobus: DTCn ;n=[0..7]  
AVS47-IB: DTCn

n	TD
7	100 s
6	50 s
5	20 s
4	10 s
3	5 s
2	2 s
1	1 s
0	no derivation

### 9.11. POWER BIAS

There are five evenly spaced discrete bias power levels that can be selected by command

Picobus: BIA n ;n=[0..5]  
AVS47-IB: BIA n

### 9.12. POWER RANGE

The TS-530A has seven remotely selectable output power ranges with one decade steps in power. In addition, the output can be remotely disabled by selecting a zero range (default state after power-on and the \*RST and PONRST commands).

Picobus: POW n ;n=[0..7]  
AVS47-IB: POW n

n	POWER RANGE
7	1W
6	100mW
5	10mW
4	1mW
3	100µW
2	10µW
1	1µW
0	output disabled

**NOTE 1:** The above power values apply for a TS-530A in standard configuration and with a heater resistance of 100Ω.

**NOTE 2:** In some units, the actual maximum heating power into a 100Ω load may be little less than 1W, depending on component spread.



## **10. SIMULTANEOUS THERMOMETRY AND CONTROL**

The AVS47-IB Computer Interface makes it possible to use a system consisting of one AVS-47 and one TS-530A for both thermometry and temperature control.

The idea here is to control the temperature in the usual way for some time, then disable the control by latching the integrator and nulling the error signal. There is no active control now, but the heater is heated by a constant power, which is determined solely by the charge accumulated in the integrator. If the system was initially in balance, its temperature will remain quite (but not perfectly!) stable for a limited time.

Once the integrator has been disabled, there is some time available for switching the AVS-47 to measure other sensors. After having done this, the control is enabled again.

The actual procedure is rather complicated, and it is described in the AVS47-IB manual in detail. This feature is not available with the primary Picobus interface.

## **APPENDICES**

A: TS-530A BLOCK DIAGRAM

B: AVS-45 COMPONENT LAYOUT

C: TS-530A DIGITAL BOARD LAYOUT

D: TS-530A ANALOG BOARD LAYOUT

E: DATA CONNECTOR

F: CIRCUIT SCHEMATICS



## Index

### A

Absolute calibration 11  
Analog input 7  
AVS-45  
    required modifications 7

### B

Banana terminals 6  
Bias power 4, 5

### C

Changing the current sense resistors 10  
Circuit ground 6  
Code switch 4, 7, 11  
Control error 5, 10  
Control polarity 4, 8  
Current sense resistors 10  
    how to change 10  
    table 9

### D

Damping 10  
Data connector 6  
    between TS530A and AVS47 5  
Data connector pin assignments 6  
Derivator 4, 5, 6, 10  
Derivator time constant 14  
Digital-to-analog converter 7  
dR/dT switch 4, 8

### E

Electrostatic discharges 6  
Enter button 4, 13  
Enter lamp 4  
Error amplifier 4  
Error meter 4, 5  
Error short switch 4  
Error signal 6

### F

Fuse 6

### H

Heater 7  
    maximum power 8  
Heater output 6, 7  
Heater power display modes 5

Heater resistance 5, 8  
Heater terminals 6

### I

Initial state 5, 12  
Input 4, 7  
Input cable 7  
Input connector 5  
Integrator 4, 6, 10  
Integrator drift 4  
Integrator time constant 4, 13

### L

Latching the integrator 4  
Linearizing the output power 6

### M

Mains ground 6  
Mains input 6  
Mains switch 5  
Mains voltage 7  
Manual set point 7  
Maximum heater current 5  
Maximum output power 4, 8, 9  
Maximum output voltage 5  
Meter switch 5

### N

Nominal output power ranges 8

### O

Operating principle 6  
Output meter 6  
Output power  
    maximum 4  
Output short -switch 5  
Overshoot 10

### P

PD controller 10  
Power amplifier 4, 6  
Power bias 4, 5, 10, 14



Power display 6  
Power meter 4, 5  
Power meter switch 5  
Power ranges 4, 5, 14  
Power-on reset state 5, 12  
Program message separator 12  
Program message terminator 12  
Proportional gain 4, 13

## **R**

Re-calibration 11  
Re-scaling the output current 8  
Relative calibration 11  
Remote control 12  
Reset state 5, 12  
Ribbon cable 5

## **S**

Saturation of output voltage 8  
Set point 4  
    Manual 7  
    Remote 7, 13  
Set point memory 7  
Signals from the TS-530 12  
Stability 5  
Step response 10  
Summing amplifier 6  
System response 10  
System stability 10

## **T**

Temperature coefficient 8  
Thermometry and temperature control 15  
TS-530  
    compatibility with 5, 6, 7

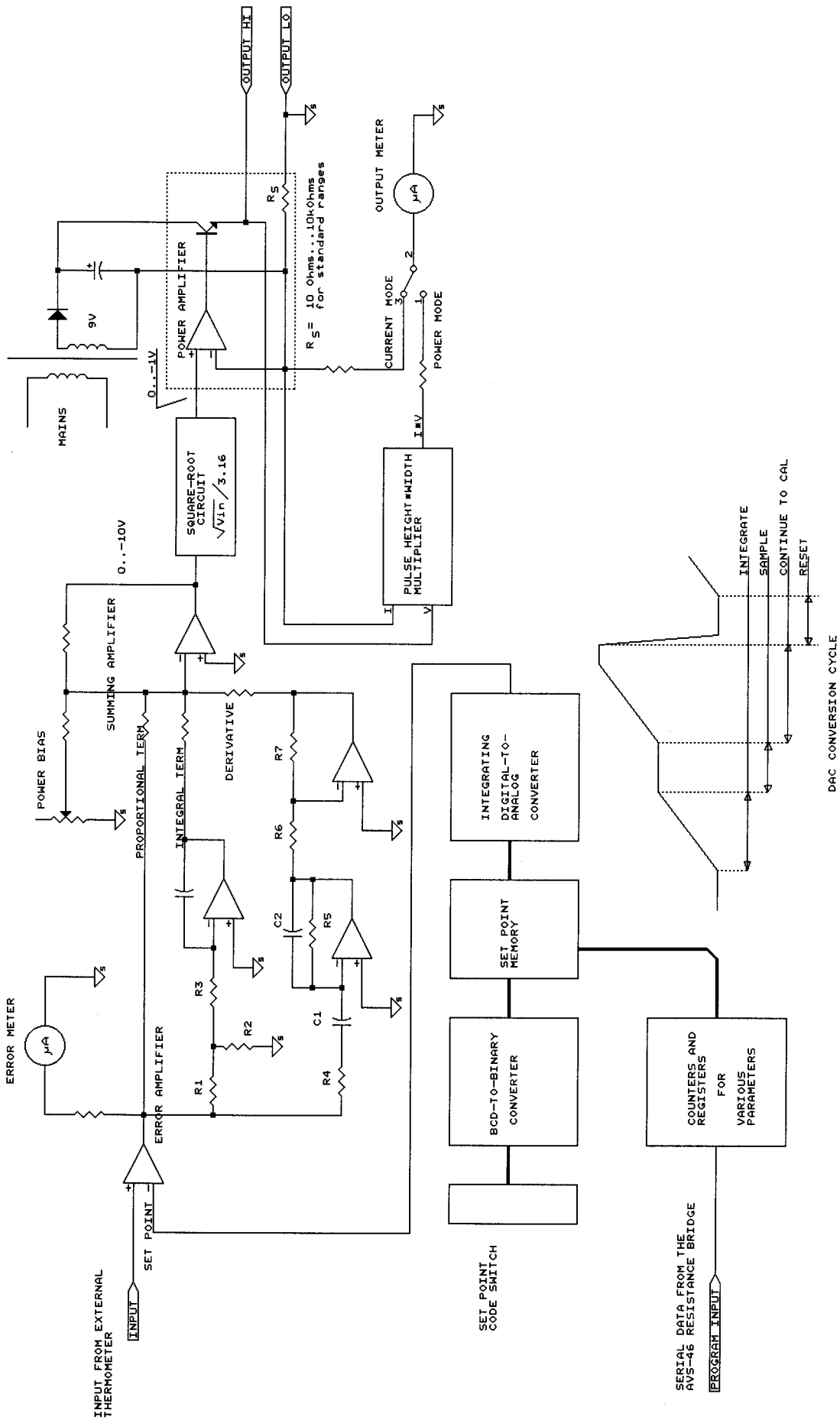

PICOMATT  
 Veromiehentie 14  
 FIN-01510 VANTAA  
 Finland

Title  
 TS-530A BLOCK DIAGRAM  
 Size Document Number  
 B 530ABLO.SCH  
 Date: January 31, 1997 Sheet 1 of 1

R417

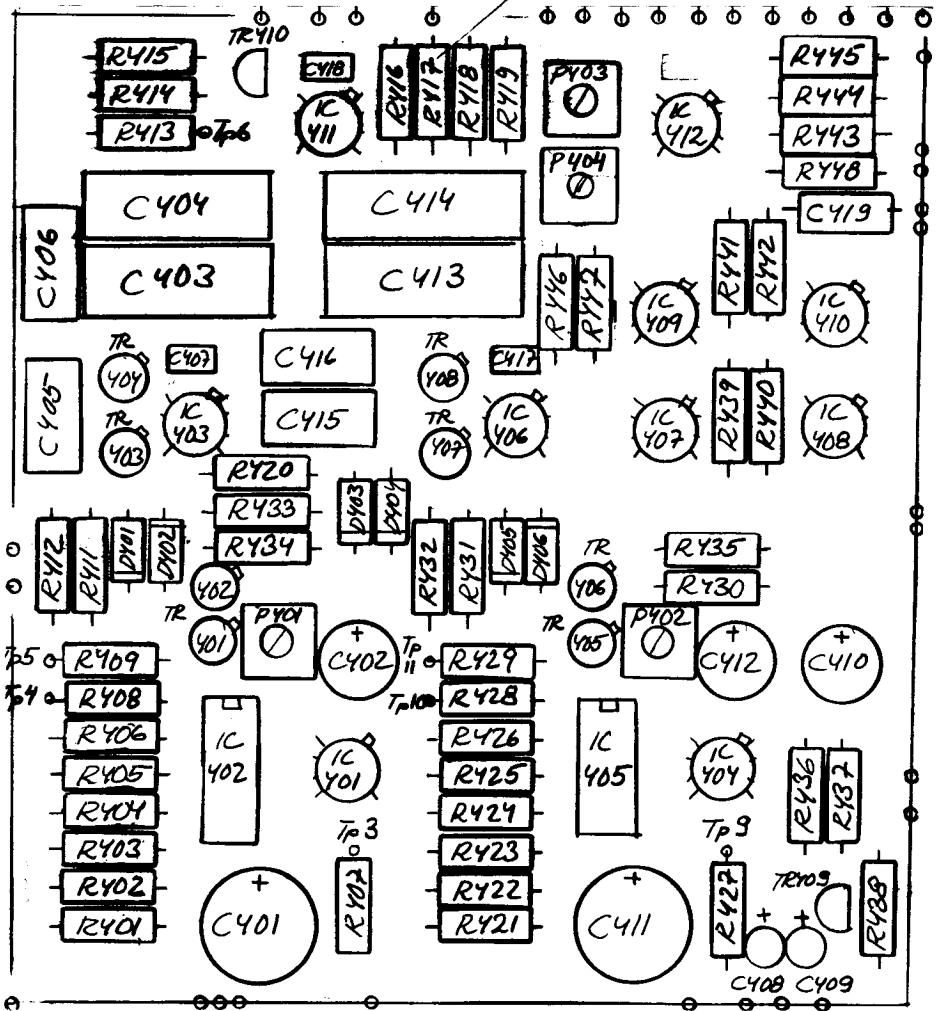

AMPLIFIER SECTION



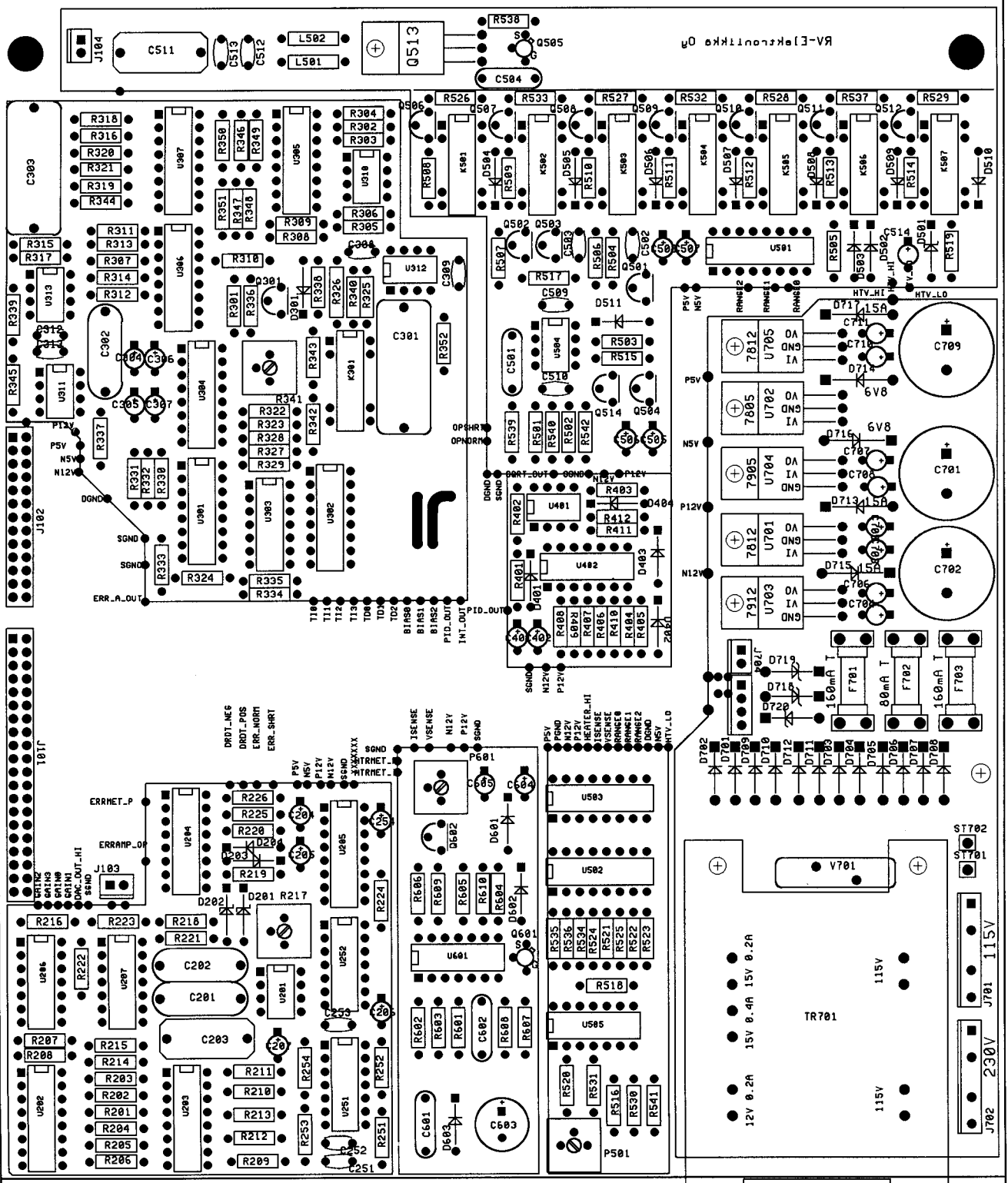

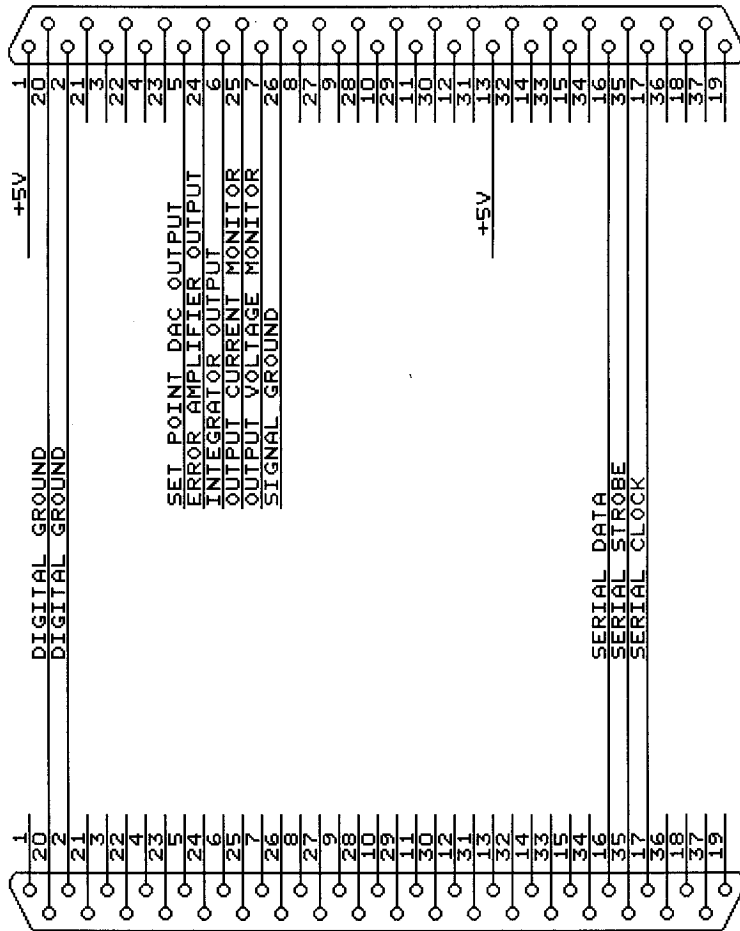

AVS-47

PROGRAMMING OUTLET

TS-530A  
INTERFACE CONNECTOR



PICOWATT  
Veromiehentie 14  
FIN-01510 VANTAA  
FINLAND

Title		TS-530 REAR PANEL CONNECTORS
Size	Document Number	REV
E	530ACONN.SCH	
Date:	January 31, 1997	Sheet of